

RECOMMENDED ACCESSORIES

Nexus accessories are designed to work in harmony with the moving parts of our beds and, in conforming with EN1970-2000 bed Standard, reduce the risk of entrapment. Use of other manufacturers' products with our beds may take a bed/mattress combination out of EN1970-2000 guidelines and may increase the entrapment risk. Neither Nexus DMS Ltd, nor any of its employees, can take responsibility for any issues arising from use of such products.



A range of matched pressure care & non-pressure care mattresses



Safety foam bumpers for siderails & head/foot boards

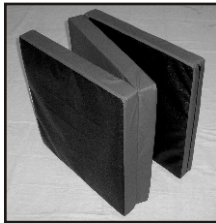

crashEX
safety mat

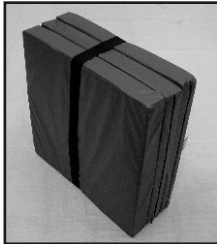

Matched siderail height extenders



easyEX
movement aid

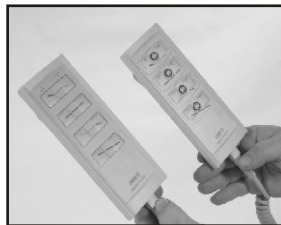

Function-lock hand control



lightEX
reading and
examination light

Nexus DMS Ltd., Unit 11, Lovett Road, Hampton Lovett Ind. Estate,
Droitwich, Worcs., UK. WR9 0QG

Tel: +44 (0) 19 05 77 46 95 Fax: +44 (0) 19 05 79 60 81

sales@nexusdms.co.uk

www.nexusdms.co.uk



Ref: NX.85.138 1009

Pro-Comm-Low

Electrically powered profiling beds

Code CB2L-200-90

Pro-Comm Low

Code CB2L-200-120

Pro-Comm Low - Wider

Code CB2L-220-90

Pro-Comm Low - Longer

Code CB2L-220-120

Pro-Comm Low - Wider/Longer

Code CB2BL-200-120

Pro-Bario™

Code CB2BLMax-200-120

Pro-Bario-Max

October 2009 edition

USER MANUAL



SAFETY NOTICE

This manual contains important information regarding the safe & proper use of the bed. It is important that any persons involved in the assembly and/or use of the bed should have read & understood its contents. Failure to do so could result in damage to the bed and may invalidate the warranty. Be aware that elements of the bed are heavy. Those involved should observe the safe lifting and handling techniques recommended under Health & Safety Regulations.

PAY PARTICULAR ATTENTION TO THE FOLLOWING ADVICE.

(also refer to page 8 for guidance on Safe Working Loads)

ASSEMBLY & INSTALLATION.

- * The bed should be assembled by suitably competent persons.
- * Ensure that the local electricity mains voltage corresponds to that marked on the main controller label before connecting to the supply.
- * Ensure that cables from actuators are plugged into the main controller correctly.
- * The fuse in the mains 'safety connector' plug should not exceed 5amps.
- * The bed should be located on a level surface & not sited on loose floor coverings .
- * The cable from the mains electricity supply must be routed clear of the lifting mechanism & castors to avoid danger of shearing or crushing.

OPERATION.

- * The brake on each castor must be applied whilst the bed is in use (see also Page 8).
- * Do not allow children underneath the bed or to use the controls.
- * Do not position objects under the lifting mechanism of the bed.
- * Always ensure that limbs or body parts of both user and carer are not protruding from the bed, are not between the siderails or into the lifting mechanism when using the powered functions.
- * Never exceed the maximum usage period of 2 minutes continuous use in any 18 mins. for any of the powered functions. Should you do so the actuator may 'close down' for a period to 'recover'.
- * If, during operation, there are any unusual noises or smells then disconnect the bed from the mains electricity power supply immediately. Ensure that no cables are trapped.
- * When raising/lowering the bed be very aware of any fixtures such as window sills, shelf units & electrical power sockets which may obstruct the raising of the bed. If necessary re-position the bed to avoid contact and damage.

RE-SITING.

- * If moving the bed to a different location always ensure that all bed functions are at their lowest position & remember to remove the plug from the mains electricity power supply.
- * Release all brakes before moving the bed, otherwise damage may occur.
- * Never use the siderails to push or pull the bed. Always use the head and foot boards.
- * With or without occupant, the bed should only be moved at slow speed & not pushed over a threshold strip greater than 2cm in height.
- * Once the bed is re-sited remember to re-apply the brakes.

MAINTENANCE & CARE.

- * All wingscrews, grubscrews & mechanical fixings should be checked regularly for tightness.
- * Use a damp cloth with normal household cleaners or warm soapy water to clean the bed. Do not use cleaning agents containing ammonia, abrasives or strong solvents.
- * Mechanical cleaning, scouring, pressure hoses or automated cleaning will damage the bed.
- * All electrical actuators are fitted with maintenance-free self-lubricating bearings & no attempt should be made to oil or grease these parts.
- * A suitably qualified service engineer should check all electrical parts & cables and mechanical functions For correct operation at least once every year.
- * Any unauthorised modifications, adjustments or alterations will invalidate the product warranty.
- * Repairs should only be carried out by a suitably qualified competent engineer.
- * Pro-beds are classed as 'double insulated' appliances, although the mains electricity safety connector supplied with each bed is not. If beds are to be used in commercial premises then customers should seek the advice of a qualified electrician regarding 'PAT2' test recommendations, as Nexus DMS Ltd cannot advise on, or undertake, such testing.

SHOULD YOU HAVE ANY DOUBTS THEN PLEASE SEEK ADVICE!

Troubleshooting.

Fault

No actuator functions when hand control operated

One actuator does not work when button is pressed.

Remedy

Check connection to mains electricity supply & fuse; check that the safety connector has not become disconnected; check connections of hand control and actuator plugs to main controller.

Check connection between actuator cable and controller.

TIP: If you have another Nexus bed of the same type (which you know is functioning correctly) try the hand control off that bed - if this cures the problem then the original hand control is

CB2L Series beds - approx.component weights

	No. per bed	Standard CB2L-200-90	Wider CB2L-200-120	Longer CB2-220-90	Longer/wider CB2BL-220-120	Pro-Bario. CB2BL-200-120
Bed end+actuator+castor	2	27.8 kg	34.3 kg	27.8 kg	34.3 kg	42.3 kg
Mattress support - head end	1	27.5 kg	42.7 kg	27.5 kg	42.7 kg	41.9 kg
Mattress support - foot end	1	24.6 kg	32.5 kg	29.4 kg	40.4 kg	34.5 kg
Main controller/cable/hand control	1	2.8 kg	2.8 kg	2.8 kg	2.8 kg	2.5 kg
Siderail - each	4	2.125 kg	2.125 kg	2.3 kg	2.3 kg	2.125 kg
Lifting pole+grab handle	1	5.6 kg	5.6 kg	5.6 kg	5.6 kg	5.6 kg

Those involved in the handling and assembly should follow Health & Safety guidelines and observe safe lifting and handling techniques.

Technical Data.

Operating voltage	~230V / 240V / 50Hz
Power reception	160 VA
Power duration	max. 2 mins in 18 mins (10%)
Appliance type B	
Safety class II	□
Weight of bed	CB2L-200-90 Low bed 126 kg (without mattress) CB2L-200-120 Wider bed 165 kg (without mattress) CB2L-220-90 Longer bed 131 kg (without mattress) CB2L-220-120 Long/Wide Bed 173 kg (without mattress) CB2BL-200-120 Pro-Bario Bed 175 kg (without mattress)
Safe Working Load <small>(refer to P.8)</small>	Pro-Comm-Low variants 200 kg (32 stones) Pro-Bario 260 kg (41 stones) Pro-Bario-Max 325 (51stones)
Product conforms to	EN 1970:08.2000
Product conforms to	EN 60601-1-1:1990

PARTS LOCATOR

When telephoning for assistance or to order spare parts it is essential we have the unique Serial Number from the bed (see Page 4). This enables us to identify the correct items for the model of bed and year of manufacture. A spare parts list is available on request.

The diagram is of a CB2DX-200-90 Pro-Comm-Deluxe - low models are similar and most parts are common to both.

(A spare parts list & other technical information sheets are available for download at www.nexusdms.co.uk)

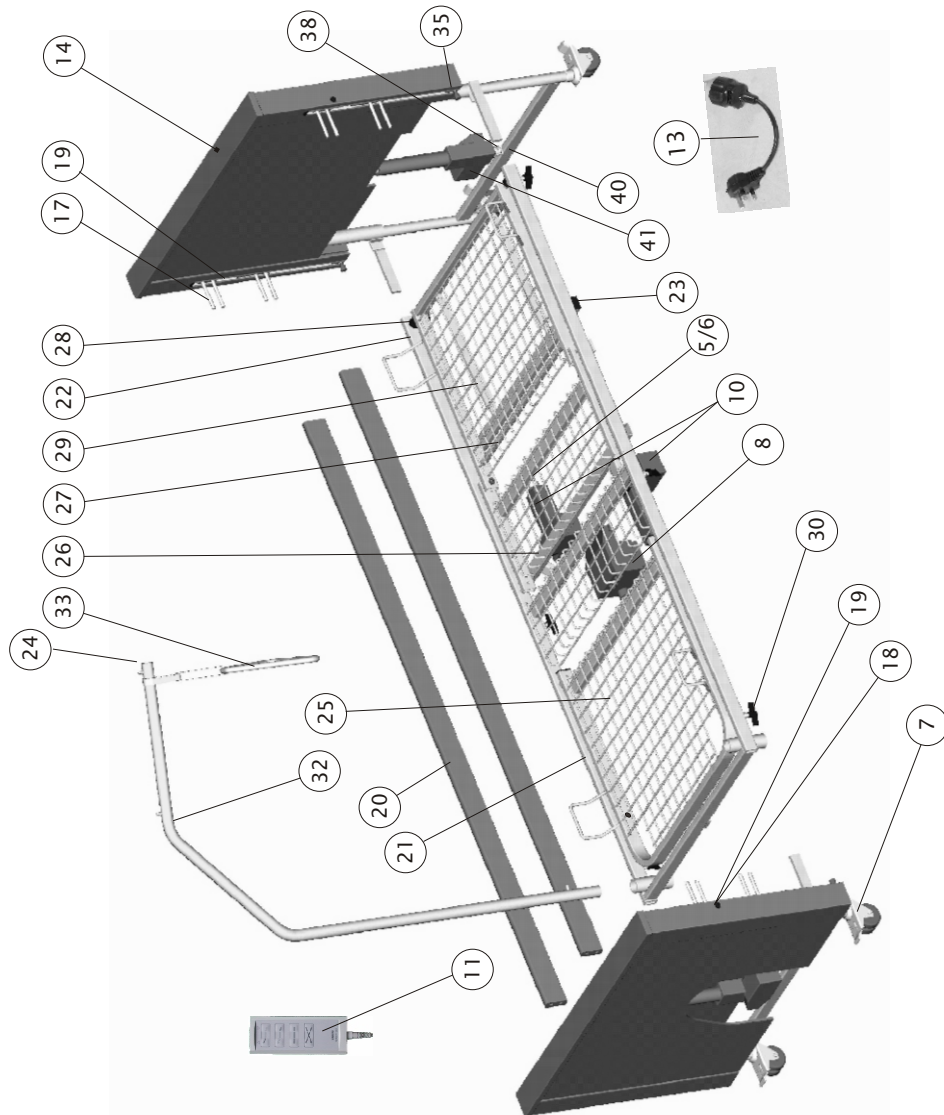

CONTENTS

2. Important safety notice.
3. Contents
Features of Pro-Comm-Low beds.
4. Product identification.
Unpacking from the transit frame.
Assembly of the mattress support.
5. Assembly of the bed ends.
Fitting the siderails.
6. Mounting the actuators.
Connecting the actuators.
Siderail finger assemblies.
7. Fitting and use of the lifting pole.
Raising & lowering the siderails.
Using Fowler position knee-break.
8. Using the electrically powered functions.
Applying & releasing the brakes.
Guidance on Safe Working Loads.
9. Guidance on mattress integrity.
Record of Maintenance / servicing.
10. Parts locator.
11. Troubleshooting.
Component weights.
Technical Data.

FEATURES OF PRO-COMM-LOW/PRO-BARIO™ BEDS.

These modular care beds have five electrically operated functions - back rest, leg rest, back rest & leg rest combined, bed height & Trendelenburg / reverse Trendelenburg. These are powered by linear actuators each of which is sealed, uses maintenance-free permanent lubrication and is ingress protected to IP54 standard.

The functions are operated using a 5-function auto-profile hand control connected to the main controller via a spiral cable. The hand control & main control are ingress protected to IP54.

All electrical functions are isolated from the mains power supply & operate at 24v DC low voltage.

A 240V mains electrical 'safety connector' is supplied. This can reduce the likelihood of damage or injury if the bed is moved before being unplugged from the mains power supply socket.

The mattress support is constructed from metal mesh which allows the mattress to breathe and so prolongs its life.

The bed is supplied complete with timber 'lift & lock' siderails together with a lifting pole and grab handle. Each castor features a simple to operate brake.

Nexus brand accessories are designed to work in harmony with the moving parts of our beds and, in conforming with EN1970-2000 bed Standard, reduce the risk of entrapment. Use of other manufacturers' products with our beds may take a bed/mattress combination out of EN1970-2000 guidelines and may increase the entrapment risk. Neither Nexus DMS Ltd, nor any of its employees, can take responsibility for any issues arising from use of such products.

PRODUCT IDENTIFICATION.

Each bed carries a CE label which identifies the type of bed, its product code and its unique Serial Number. **DISPLAY OF THIS CE LABEL IS A LEGAL REQUIREMENT. IT MUST NOT BE REMOVED.**

Should you ever require advice or spare parts then it is essential that you quote the Serial Number - this enables us to match parts and advice to your particular bed.



UNPACKING BED SECTIONS FROM THE TRANSIT FRAME.

(This procedure is better undertaken by two people.)

PLEASE REFER TO THE SAFETY NOTICE ON PAGE 2 BEFORE ATTEMPTING TO UNPACK AND ASSEMBLE THE BED.

- Carefully remove the ties and take the lifting pole out from the side of the unit.
- Remove the ties, lift the timber siderails upwards & clear of the bed.
- Each half of the mesh mattress support locates on transit brackets & is held in place by two wingscrews or grubscrews at its lower end (one each side). Unscrew the two fixings and lift one half of the mattress support clear of the transit brackets. Lift upwards until it is clear of the bed ends. Repeat the process for the second half of the mattress support.
- Loosen the two grubscrews on the underside of each transit bracket and with a second person supporting one of the bed ends carefully slide the other bed end off the brackets. Remove the transit brackets completely and retain in a safe place should you ever need to re-pack the bed for transit or storage.

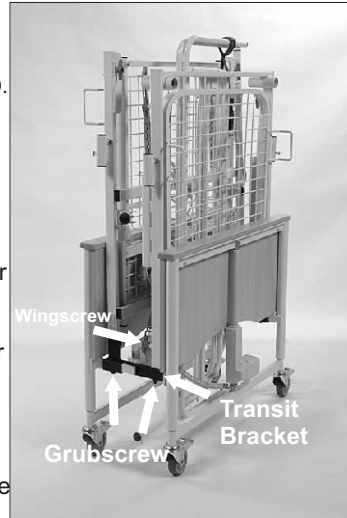

This picture is of a Pro-Comm Standard bed. Unpacking instructions for Pro-Comm-Low models are identical.

ASSEMBLY OF THE MATTRESS SUPPORT UNIT (not necessary on Pro-Bario-Max)

- Position the two halves of the mattress support on their sides facing each other as shown. Note the position of the locating hole in the joining bar. Unscrew the two grubscrews but do not remove completely (4 on Bario).
- Slide the sections together, ensuring both fit fully together until the outer tubes touch each other.
- Position a clevis pin **from the outside** through the outer tube and inner joining bar - locking the 2 halves of the mattress support assembly together. Attach the 'R' clip through the small hole at the inner end of the clevis pin.
- Tighten the grubscrews on the underside of the mattress support very securely using an Allen key. These should be rechecked for tightness periodically - refer to Page 2.

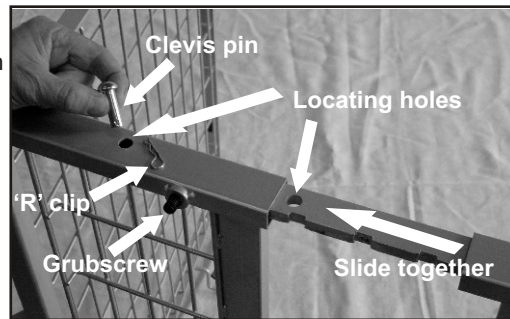

FOR EASE OF ASSEMBLY YOU SHOULD ALWAYS FIT THE 2 CLEVIS PINS AND 'R' CLIPS BEFORE TIGHTENING THE 2 (or 4) GRUBSCREWS.

MATTRESS INTEGRITY.

Should a mattress cover be damaged then body or other fluids can pass through and contaminate the inner core creating the potential for cross-infection.

It is therefore recommended that a frequent inspection of mattress covers is undertaken to inspect for damage, such as holes or cuts. The inner core of the mattress should also be inspected for signs of staining or contamination.

Should there be damage to a cover then it should be disposed of safely. Should there be contamination to the inner foam core then it cannot be decontaminated and should therefore be disposed of safely. Inner cells of an Optima air-float mattress system can be decontaminated.

RECORD OF MAINTENANCE & SERVICING

Use this page to keep a record of repairs to and servicing of this bed.

From the identification label attached to the bed (see Page 4) make a note of the following:

BED TYPE: Pro-Com-Low Pro-Bario

PRODUCT CODE: CB2L/CB2BL-.....-.....

SERIAL NUMBER:

(A spare parts list & other technical information sheets are available for download at www.nexusdms.co.uk)

DATE:	DESCRIPTION:
-------	--------------

USING THE ELECTRICALLY POWERED FUNCTIONS.

BEFORE USING ANY POWERED FUNCTION PLEASE READ THE SAFETY NOTICE ON PAGE 2.

Pro-Comm-Low and Pro-Bario beds are fitted with an auto-profile/function-lock hand control similar to the one pictured. This controls the independent operation of the back-rest, leg-rest, bed height & Trendelenburg functions. It also allows the back-rest and leg-rest to be operated simultaneously using just one button. It allows any or all functions to be locked using the special 'key' provided - inserting and turning clockwise to lock (closed padlock pictogram) or anti-clockwise to un-lock (open padlock pictogram). The 4 buttons to the left control the 'raise' functions & the 4 buttons to the right the 'lower' functions.

Each button carries a pictogram to denote its function.

A clip on its rear allows it to be positioned conveniently on a siderail.



WARNING: When using the Trendelenburg/Reverse functions only the 2 brakes at one end of the bed should be applied. The 2 brakes at the other end MUST be left

APPLYING & RELEASING THE BRAKES.

For safety reasons the brake on each castor must be applied when the bed is in use.

They must be released before moving the bed.

WARNING: When using the Trendelenburg/Reverse functions **only** the 2 brakes at one end of the bed should be **applied**. The 2 brakes at the other end **MUST** be left released.

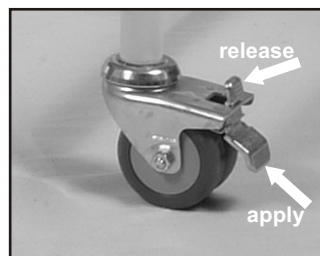

GUIDANCE ON SAFE WORKING LOADS

The **Safe Working Load** **MUST NEVER** be taken as the maximum user weight.

In common with other manufacturers we quote a Safe Working Load for each of our beds. When a bed is tested, a **static load** is evenly distributed over the whole surface of the bed. Remember when a bed is in use that the load is rarely static or evenly distributed. Should a visitor, for example, sit down heavily on one side of the bed then the shock load at that point will be extreme, the load will be uneven & the total combined weight may **exceed** the Safe Working Load. The **SWL** must take account not only of the weight of the user but also the weight of the mattress, bed linen & other items loaded on to the bed eg. Air pump for air-driven mattress.

You should also take account of any likely weight gain by the user in the future.

Typically, a mattress could weigh 20kg; an air-driven system could be as much as 30kg; a couple of pillows 3kg; bed linen around 12kg - **the total of such items, together with anything else placed on the bed, PLUS the weight of the user must NEVER exceed the Safe Working Load.**

Neither Nexus DMS Ltd, nor any of its employees, can accept responsibility for any issues arising from overloading a bed. Should damage result from such actions then any necessary repairs will not be covered under warranty.

ASSEMBLY OF BED ENDS & SIDERAILS

(Siderail finger assemblies are pre-assembled to the bed ends on this style of bed)

1. First identify the 'head' end of the mattress support unit (lifting pole sockets). The bed-end assemblies are identified by the numbered tag on each actuator plug: 3=Foot; 4=Head.
2. Place each of the three assemblies on their sides - head to head & foot to foot.
3. Unscrew the two wingscrews or grubscrews on the underside at each end of the mattress support unit (picture A)
4. Raise the mattress support unit from the floor & slide the head-end 'T' brackets fully into the tubular sections. Securely tighten the wingscrews or grubscrews by hand.
5. Repeat (4) above for assembly of the foot-end - but do not tighten these two wingscrews.
6. **REFER TO PAGE 6 FOR MOUNTING & CONNECTING THE ACTUATORS.**
7. Carefully pull the bed over & on to its castors.
8. With assistance, take the weight off the **foot end** castors by lifting the mattress support unit at that end.
9. Very carefully slide out the bed end until you can see approx. 2.5" (65mm) of the 'T' brackets. (Picture B) - do NOT remove bed end completely. Lower onto its castors.
10. Take two siderails & slide onto the finger assembly at the **head** end. Holding the top rail, lift until the rails lock into their upper position.
11. Lift the other end of the rails & slide onto the finger assembly at the foot end. (Picture C)
12. Repeat for the two rails at the other side of the bed.
13. Slide the bed end back fully into the tubular section of the mattress support & re-tighten securely the two wingscrews or grubscrews .

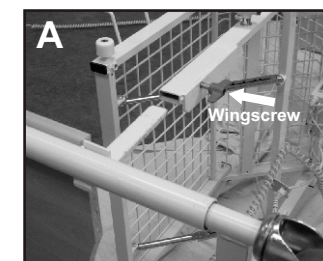

MOUNTING THE ACTUATORS TO THE MATTRESS SUPPORT UNIT.

NOTE: This procedure is not necessary on Pro-Bario-Max which has a 1-piece mattress support unit

Once the 2 halves of the mattress support unit have been assembled it is necessary to attach the free ends of the back-lift and leg-lift actuators to their respective mounting points on the mattress support assembly. Note that the main controller is mounted to the leg-lift actuator on beds fitted with LA27 (black) actuators. Where the bed has LA31 (grey) actuators then the main controller is mounted separately on the mattress support unit. On beds fitted with the LA27 (black) main controller ensure that the plug sockets face DOWNWARDS towards the floor.

1. Remove the 'R' clip and clevis pin from each of the 2 mounting brackets.
2. Swing each actuator into place, positioning the end of its arm centrally in the mounting bracket legs - carefully aligning all 3 holes.
3. Replace each clevis pin and re-fit the 'R' clip securely.

BACK-LIFT ACTUATOR



LEG-LIFT ACTUATOR

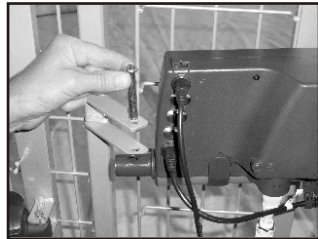

CONNECTING THE ACTUATORS TO THE MAIN CONTROLLER.

There are 4 actuators, each is connected to the main controller by a spiral cable and multi-pin plug.

Each plug carries a numbered tag which corresponds to a numbered socket on the main controller. The plugs are 'keyed' & will only insert if correctly aligned in the socket.

There is a retaining strap over the sockets - this should be released, using the tip of a small screwdriver, before attempting to fit the plugs & snapped back afterwards to 'lock' the plugs in place.

Assemble each of the numbered plugs & then fasten the spiral cables into their retaining loops on the underside of the bed so that they do not trail on the floor.

Take great care to ensure that cables are clear of actuators & that there is sufficient slack to allow for the movement of bed parts.

SIDERAIL FINGER ASSEMBLIES

Should it ever be necessary to take apart and re-fit the siderail finger assemblies then it is essential that they are re-fitted correctly to ensure correct operation and maintain the approved measurements - refer to this diagram.

To retain the siderails in their lowered position an end stop/closure is fitted to the aluminium track during production - see picture. This should be removed by unscrewing partially until the screw is free of its locating hole in the aluminium track and sliding from the bottom of the track as a complete assembly. When refitting ensure that the washer is located on the **outside** of the track and that the **screw** locates in its **locating hole** through the rear face of the track.

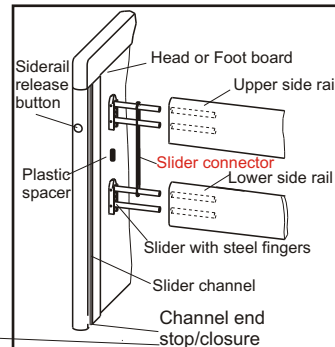

NOTE: CORRECT FITTING OF THE **SLIDER CONNECTOR** (WIRE LOOP) IS VITAL - IT **MUST** BE POSITIONED AROUND THE **UPPER** FINGER OF EACH PAIR.

FITTING THE LIFTING POLE

1. There is a socket for the lifting pole on each side of the bed at the head end.
2. Insert the lifting pole into either the left or right hand socket.
3. Rotate the pole until the pin on the pole locates in the corresponding groove in the socket - this keeps the pole central & securely positioned for use.
4. Hang the grab handle over the end of the pole between the two vertical pins & adjust the strap to the required length.
5. The pole can be lifted slightly to free the pin & swung out of the way when not in use. It must NOT bear any weight when in this position.

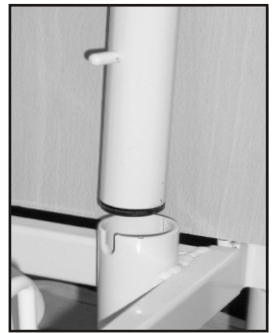

RAISING & LOWERING THE SIDERAILS

TO RAISE:

Hold the UPPER siderail at the head end & slide up the channel until the locating pin engages with a 'click'. Both upper & lower rails are now locked in the upper position, correctly spaced. Repeat the procedure at the foot end.

For occupant safety always 'lift & lock' the siderails at the head end first.

TO LOWER:

Hold the UPPER siderail & lift slightly until it stops. This action 'unlocks' the release button on the side of the head/footboard.

Press & hold the button & gently lower the siderails until they rest on the stop at the bottom of the track.

NEVER let go of the rails & allow them to drop. For occupant safety always lower the rails at the foot end first

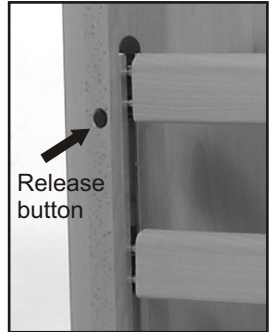

ADJUSTING THE FOWLER POSITION KNEE-BREAK

The Fowler position knee-break is adjusted on ratchet mechanisms attached to the leg lift section and can be adjusted both manually and electrically. There are 6 positions available so that you can achieve the correct angle for a particular users knees.

MANUAL ADJUSTMENT: Raise the leg lift section electrically to a chosen height and then, holding one of the mattress retaining handles, lift the foot section until it 'clicks' and remains at the position you require. To lower - lift fully to its highest position (you will hear 'clicks') then lower until the foot section rests on the mattress support unit.

ELECTRICAL ADJUSTMENT: Raise the leg lift section electrically until you achieve the knee angle required. Lower electrically until you hear 1 'click' then raise electrically to the height you require. The chosen angle will be maintained. To lower - use the hand control and lower electrically until flat.